



Telehandler

SCORPION

960 756 746 741 736 635 1033 732

CLAAS



Retrieving bales, loading and unloading general or free-flowing goods, removing and distributing fodder, lifting pallets and heavy loads, transporting goods, driving active tools, maintaining tracks, clearing snow – there’s more and more to do for telehandlers in agriculture. Especially when they offer such a wide variety of attachments as the SCORPION. As a result, this telehandler can replace up to five specialised machines on your farm.

Large series:

- Heavy duty > 5 t
SCORPION 960 / 756. Ideal for businesses with large volumes of materials and very high demands regarding productivity, reliability and comfort.
- Specialist > 4.5 t
SCORPION 746. Productive, reliable and comfortable like the heavy-duty models. Preferred for use with medium to large material handling volumes.

Small series:

- Specialist > 3.5 t
SCORPION 741 / 736. For businesses with medium material handling volumes which need a compact telehandler that boasts good manoeuvrability, lifting height and versatility.
- All-rounder < 3.5 t
SCORPION 1033 / 732 / 635. Ideal for businesses with light material handling volumes and a wide range of applications. Compact design and good manoeuvrability are the focus. If you want to achieve high lifting heights, go for the SCORPION 1033.



Large series		Heavy duty 6 t	Heavy duty 5.6 t	Specialist 4.6 t
SCORPION		960 VARIPOWER PLUS	756 VARIPOWER PLUS	746 VARIPOWER

Max. lift capacity	kg	6000	5600	4600
Max. lift height	m	8.79	7.03	7.03
Output at 2300 rpm (ECE R 120)	kW/hp	115 / 156	115 / 156	100 / 136
Max. torque at 1600 rpm	Nm	609	609	500

Small series		Specialist 4.1 t	Specialist 3.6 t	All-rounder 3.5 t	All-rounder 3.3 t	All-rounder 3.2 t
SCORPION		741 ¹ VARIPOWER 2	736 ¹ VARIPOWER 2	635 ¹ VARIPOWER 2	1033 ¹ VARIPOWER 2	732 ¹ VARIPOWER 2

Max. lift capacity	kg	4100	3600	3500	3300	3200
Max. lift height	m	6.93	6.93	6.13	9.75	6.93
Output at 2300 rpm (ECE R 120)	kW/hp	100 / 136	100 / 136	100 / 136	100 / 136	100 / 136
Max. torque at 1600 rpm	Nm	500	500	500	500	500

¹ Also available as the robust, economical TREND entry-level model



Your choice of ground drives.
Page 14



SMART LOADING driver assistance systems to take the strain off work.
Page 26



Reliable Deutz engines.
Page 10



Four steering modes for any manoeuvre.
Page 21



An arm you can rely on.
Page 22



A workplace designed for comfort.
Page 30

SCORPION Telehandlers	2
Technology in detail	6
CLAAS POWER SYSTEMS	8
Engine	10
Cooling system	12
VARIPOWER ground drive	14
SCORPION TREND	16
Ground drive	18
Chassis	20
Loader unit	22
Implement carrier and telescopic arm	24
SMART LOADING	26
Hydraulic system	28
Cab and comfort	30
Comfort	32
Display and control instruments	34
Cab equipment	36
Camera and safety systems	38
Lighting	39
SCORPION TREND equipment	40
Servicing	42
CLAAS Service & Parts	44
Load capacity charts	46
Features	50
Specifications	51

Find out more about the SCORPION.
scorpion.claas.com



Scan me.



- 1 Lift capacities from 3.2 to 6.0 t
- 2 Deutz engines with up to 115 kW / 156 hp, Stage V or IIIA
- 3 Infinitely variable hydrostatic ground drive with intelligent SMART ROADING function
- 4 DYNAMIC COOLING: Electronic control of fan speed and reversible fan
- 5 Powerful hydraulic system for productive work
- 6 Third and fourth control circuits, leakage oil line and pressure-free return available
- 7 DYNAMIC POWER and fine-tuned control of working hydraulics for optimal sensitivity and precision even at great heights
- 8 External pressure relief for the third control circuit on the telescopic arm
- 9 Side support for the telescopic arm available for all models
- 10 SMART LOADING driver assistance systems
- 11 Ergonomic cab with large windows for maximum visibility
- 12 Choice between 3.5" instrument cluster display and 7" display
- 13 Intelligent parking brake with automatic function
- 14 Manual crab steering as fourth steering mode
- 15 Maximal tyre size: 600/55-26.5

Economic driving.
 CLAAS POWER SYSTEMS (CPS).

CPS | CLAAS
 POWER
 SYSTEMS

What drives us: optimal components interacting optimally.

Your CLAAS machine is much more than the sum of its individual parts. Top performance is only possible when all of the parts are ideally matched and work together optimally.

In CLAAS POWER SYSTEMS (CPS), we have brought together top-quality components to create an intelligent drive system. Full engine output only when you need it. Drives that are suited to the way you use your machines. Fuel-saving technology that quickly pays off.





Advanced high-performance engines.

The high-torque 4-cylinder Deutz engines featuring 4-valve technology and turbocharger deliver an output of 100 kW (136 hp). The SCORPION 960 and 756 models are fitted with 115 kW (156 hp) engines. Both engine variants have plenty of power in reserve, even for the toughest pushing and material handling tasks. Intelligent engine control combined with the SMART ROADING function always keep the engines running within the optimal speed and torque range. This substantially reduces your fuel consumption.

- High performance optimum thanks to CPS
- Optimal fuel consumption / power ratio
- Intelligent engine control
- Maximum torque of 500 and 609 Nm respectively

SCORPION	Engine output	Cubic capacity
	kW / hp	litres
960	115 / 156	4.1
756	115 / 156	4.1
746	100 / 136	3.6
741	100 / 136	3.6
736	100 / 136	3.6
635	100 / 136	3.6
1033	100 / 136	3.6
732	100 / 136	3.6



Effective contribution to climate protection.

The state-of-the-art diesel engine helps comply with applicable greenhouse gas emission limits. It combusts fuel more efficiently and emits up to 15% less CO₂. All models complying with the Stage V emissions standard feature SCR catalytic converters for reducing nitrogen oxide emissions, while a diesel particulate filter (DPF) with integrated diesel oxidation catalytic converter (DOC) takes care of reducing carbon monoxide and hydrocarbon emissions.

Work without interruptions.

The status of the diesel particulate filter is shown on the display at all times. You'll always know when the next regeneration is due, which is performed automatically without manual intervention. In unfavourable conditions or in an emergency, regeneration can be suppressed by pressing a switch. The long intervals between regenerations ensure that you can complete long, uninterrupted working cycles.

Enough fuel for long working days.

The large fuel tanks are located under the cab on the left of the machine, providing optimal protection and ease of access. The solid steel underbody protection ensures maximum safety in everyday operations.

- Large tank volumes allow longer operating periods without needing to stop.
- Minimises the risk of damage when working in tough conditions

SCORPION	960 / 756	746-732
Fuel tank	190	150
Urea tank	20	10



Easily accessible AdBlue®-filler neck filler neck for efficient exhaust gas aftertreatment



The diesel particulate filter is regenerated automatically.



Lockable fuel tank behind the cab

Intelligent cooling.

A clean air supply comes as standard.

The SCORPION takes air in via large filters located in the clean, dust-free section of the machine. This minimises soiling of the cooling fins with straw, grass and silage, and large dust and dirt particles never even enter the air circuit.

- Direct route to the air filter
- Problem-free use, even in high-dust environments
- Low maintenance requirements

Even cleaner operation as an option.

If you mainly work in high-dirt environments, it is advisable to fit a negative-pressure preseparator. The preseparator is integrated into the engine compartment and eliminates coarse dust and dirt particles from the intake air before it enters the system. This significantly extends air filter maintenance intervals.



The reversible fan keeps the large ventilation surfaces free of straw and dirt particles



As a result, cooling capacity is consistently maintained even when working in extremely dusty conditions

Efficient air flow.

Cold air enters through large intake surfaces in the clean front part of the machine and is drawn through the engine compartment. Engine heat is discharged from the engine compartment via a designated exit opening at the upper rear. This intelligent air flow design prevents dust turbulence underneath the machine.

During road transport or when operating with part loads only, a lower fan speed is often sufficient. DYNAMIC COOLING detects the requirements of all cooling units via thermosensors and electronically adapts fan speeds as required.



DYNAMIC COOLING saves both energy and fuel.



Automatic cleaning with reversible fan.

The reversible fan clears air intake surfaces fully automatically of dirt and dust particles. The fan direction is reversed at regular intervals. The time interval for this is preset, but can be changed by CLAAS Service if required. The fan can also be reversed manually at any time at the push of a button.

- A truly smart machine
- Long operating periods
- Easy cleaning of intake surfaces
- Reduced maintenance requirements
- Reduced driver fatigue
- Full focus on the work at hand



Avoidance of radiator soiling thanks to the reversible fan

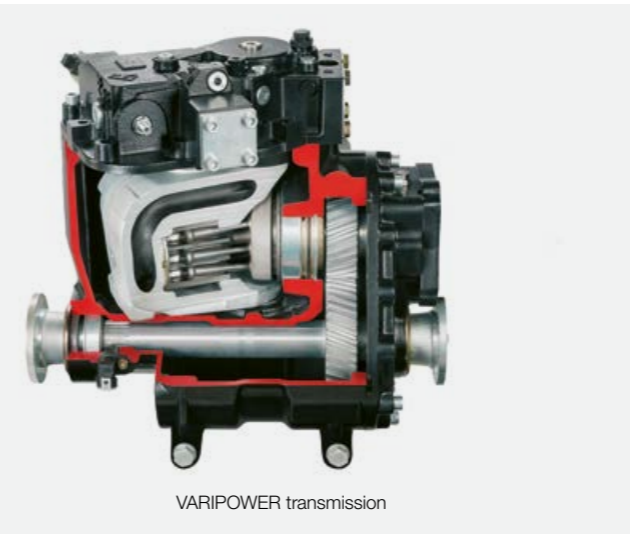
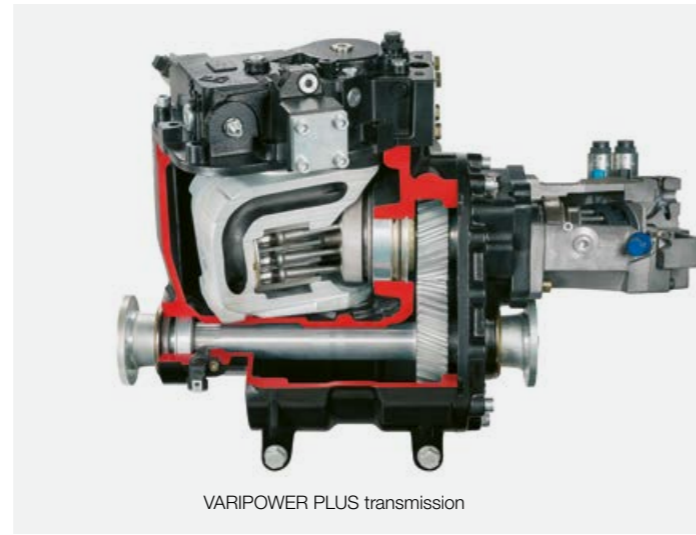

All the power you need, and infinitely variable.

The SCORPION VARIPOWER offers you a choice of three hydrostatic ground drives. All are electronically controlled and feature outstanding drive characteristics. Operators benefit from precise control and perfectly metered thrust in any driving range.

- 1 VARIPOWER PLUS with two high-torque hydraulic motors for models up to 40 km/h
- 2 VARIPOWER with wide-angle motor for the 746 model with up to 40 km/h
- 3 VARIPOWER 2 with twin motor for the compact series with up to 40 km/h

Extra powerful: VARIPOWER PLUS.

The SCORPION 960 and 756 models are fitted with the VARIPOWER PLUS gearbox as standard. Along with a wide-angle hydrostat (45°), this system features a swivelling variable displacement motor with a 32° swivel angle, which delivers significantly more power in all operating ranges.

- Maximum agility
- Maximum thrust
- Maximum fuel efficiency thanks to SMART ROADING

Extra comfortable: VARIPOWER PLUS.

Thanks to the VARIPOWER transmission with 45° maximum swivel angle (wide-angle hydrostat), the SCORPION has a top speed of 40 km/h, infinitely variable. Ground speed and thrust are coordinated with each other at all times. This keeps fuel consumption low even when operating at high capacity.

- High level of agility
- High level of thrust
- Highly fuel efficiency thanks to SMART ROADING

Extra efficient: VARIPOWER 2 with twin motor.

The VARIPOWER 2 drive is alternatively also available with a twin motor. This drive not only runs quietly and efficiently, but it is also highly reliable, as there is no reduction. The oil is actively extracted from the housing to keep the drive dry and eliminate churning losses.

Both driving gears share a shaft and a swash plate. This ensures that they run in absolute synchronicity. As they run in opposite directions, their axial forces balance each other out. This significantly reduces friction losses in the shaft bearing.

SCORPION	960	756	746	741	736	635	1033	732
VARIPOWER PLUS, 40 km/h	●	●	-	-	-	-	-	-
VARIPOWER, 40 km/h	-	-	●	-	-	-	-	-
VARIPOWER 2, 40 km/h	-	-	-	●	●	●	●	●
30-km/h variants	○	○	○	○	○	○	○	○
20-km/h variants ¹	○	○	○	○	○	○	○	○

● Standard ○ Optional - Not available

¹ All models, irrespective of the gearbox fitted, are also available as 20-km/h versions ("self-propelled work machines").

Comes as standard: SMART ROADING

SMART ROADING adjusts the engine speed to the power level required. The operator only needs to set the ground speed with the ground drive pedal. The engine speed is raised or lowered automatically depending on the loads applying to the diesel engine. This not only lowers the noise level when the top speed is reached, but also reduces the diesel consumption during both road transport and on-farm material handling operations.





Infinitely variable hydrostatic ground drive.

In a SCORPION TREND you can rely on a proven hydrostatic ground drive that has been developed continuously over decades. The machine offers comfortable, infinitely variable, economical driving characteristics at ground speeds from 0 to 30km/h (optional 20 km/h).

Powerful working hydraulics.

Whether you are handling heavy loads or would like to speed up your loading cycles – you can always rely on the powerful hydraulic system. Proportional valves allow precise control of the individual loader unit functions.



Rapid fill level checks.

- Easy checking of the hydraulic oil fill level via a sight glass
- Optionally via the 3.5" matrix display

Extra robust: SCORPION TREND.

If your business requires less transport, pulling or pushing power, but instead focuses on a wide range of loading activities, the economical SCORPION TREND will pay off. The models in this series feature an infinitely variable hydrostatic drive which enables highly precise, sensitive work at any speed. They offer the same reliability, stability and lifting power as the VARIPOWER models. The TREND equipment is somewhat more basic and therefore more economical.

SCORPION TREND	741-732
Ground drive	Hydrostatic ground drive with one driving range and a max. top speed of 30 km/h
Hydraulic capacity	106 l/min, gear pump with throttle control block
Operation	Control lever with basic functions
Steering mode adjustment	Manual
Hand throttle, creep speed facility	Manual
Display	3.5" matrix display (black and white)

Working hydraulics SCORPION TREND		741	736	635	1033	732
Type		Gear pump				
Valves		Throttle control block				
Max. pump capacity	l/min	106	106	106	106	106
Max. operating pressure	bar	270	270	240	270	240

This ensures safe operation, at any ground speed.



The brake pedal with inching function reduces fuel consumption and brake wear

High-precision control at any engine speed.

Pressing lightly on the brake pedal with inching function continuously reduces your ground speed. The engine speed stays the same. Pressing the pedal through to the floor automatically sets the ground drive to zero and activates the service brake. This allows accurate, precisely metered driving at any engine speed.



Constant speed.

The creep speed facility of the SCORPION VARIPOWER is ideal for operations such as sweeping or litter spreading, which call for a high oil flow rate at low ground speeds. The ground speed is easily and conveniently adjusted via the potentiometer, and the required diesel engine speed is set via the hand throttle. The creep speed facility can be used in all speed ranges.

- 1 Electronic creep speed facility
- 2 Electronic hand throttle

Accelerating by hand.

The hand throttle, which can be combined with the creep speed facility, can be used to deliver constant output from the working hydraulics.



Safe transport.

For the SCORPION, there is a choice of a two-line air brake system or a hydraulic brake. This provides safe braking capability for even heavy trailers such as when transporting straw on the road.

Automatic parking brake.

When you leave the driver's seat, turn off the engine or lower the ground speed to 0 km/h, the SCORPION automatically activates its electrohydraulic parking brake. The brake is released as soon as you depress the accelerator pedal and select a direction of travel. This feature is particularly helpful in hilly terrain. A toggle switch is additionally available for manual activation.



The toggle switch allows the parking brake to be operated manually

Adjusts perfectly to any kind of terrain.

Stability and safety in any position.

The strong axle design and self-locking differential with a 45% lock value or differential lock with a 100% lock value in the SCORPION 960-746 provide maximum safety when working in difficult conditions. The front of the SCORPION features a planetary steering drive axle with a maximum steering angle of 35°, which ensures outstanding agility. The rear is equipped with an oscillating planetary axle with an 11° oscillation angle each side in the SCORPION 1033-635 and a 10° oscillation angle each side in the SCORPION 960-746 to provide extra stability.

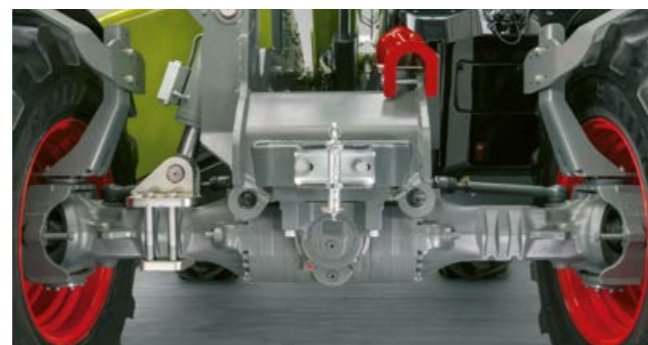

1033 chassis

Levelling system for heavy loads.

The SCORPION 960 and 1033 allow hydraulic levelling between the frame and front axle within +/- 8°. This feature is activated via a toggle switch in the cab, and a spirit level is provided within easy view of the operator. This provides maximum stability in uneven terrain and allows you to work accurately even at high lifting heights.



960 chassis

For your added safety when working on slopes, an indicator is fitted above the front axle to show the machine's horizontal angle.

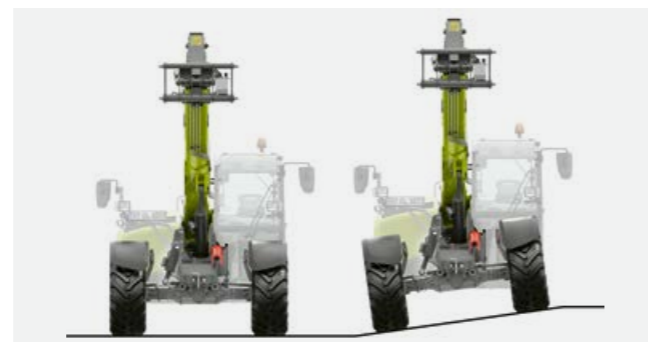

Hydraulic levelling. Standard in the SCORPION 1033 and 960



Greater off-road safety thanks to hydraulic levelling

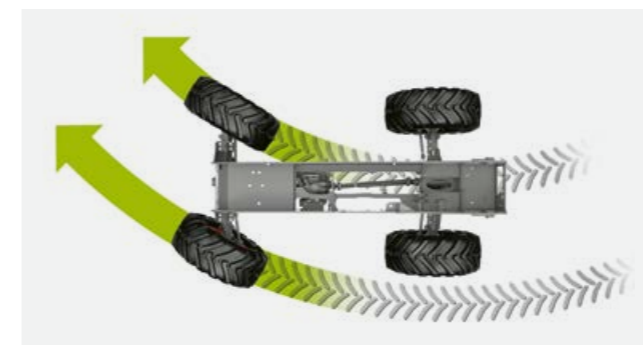

1 Front-wheel steering

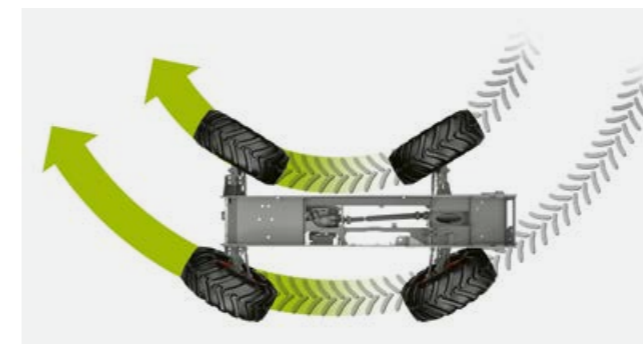

2 All-wheel steering



3 Crab steering



4 Manual crab steering

Steering modes for every application.

Four steering modes provide unbeatable manoeuvrability, even in the tightest of spaces. Manual crab steering makes the machine even more agile through front-axle steering.

- 1 Front-axle steering
- 2 All-wheel steering
- 3 Crab steering
- 4 Manual crab steering

Change steering modes quickly, precisely and easily

In the SCORPION VARIPOWER models, the steering modes can be changed quickly and easily even while driving, with the axles being synchronised electronically. The rotary pushbutton for selecting the steering mode is located within easy reach at the right of the dashboard.

For manual crab steering, first manoeuvre the rear axle manually into the required position before switching to front-axle steering mode. The selected steering mode is shown in the display so that you always see it at a glance.

In the TREND models, the central axle position is synchronised manually. The mode is conveniently switched via a lever.



Greater precision with manual crab steering

A powerful arm on your farm.

SCORPION operators can rely on very powerful working hydraulics and a robust telescopic arm with optional side support that delivers outstanding torsion resistance and load capacity. Not only that, they are also supported by smart automatic functions such as bucket return, end-position damping as standard and regenerative hydraulics, which boost productivity while easing the operator's workload.



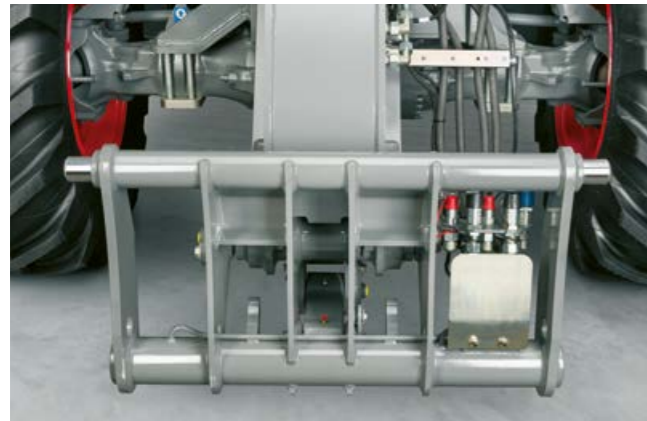

Designed for hard work.

The robust implement carrier is clearly visible from the SCORPION cab and designed for any operating conditions. Strong locking pins (50 mm) ensure that any implements can be attached securely with minimal wear, mechanically or hydraulically as preferred. The hydraulic connections are easily accessible and well-protected. The attachments can be simply changed via a touch key switch or a toggle switch.

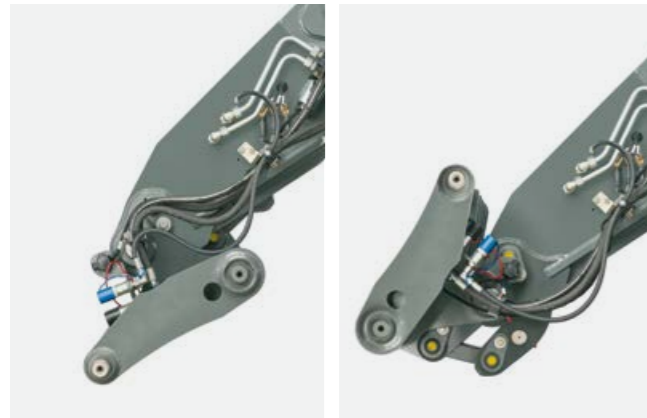

152-degree dumping angle.

The implement carrier features an unusually large rotation angle of up to 152°, making it ideal for moving bulk goods, especially sticky goods and materials. The SCORPION 1033 VARIPOWER model is optimised for stacking tasks at high working heights and therefore features a slightly smaller rotation angle of 126°.

Large rotation angle of up to 152° for easy unloading of bulk goods

Powerful at any height.

The telescopic arm has excellent torsion resistance, so operators can continue to work without difficulty even close to capability limits. The load capacity remains impressive even at maximum extension. The brush on the lift mast prevents any build-up of dirt as the telescopic arm is retracted. A side support is available for the telescopic arm in all SCORPION models.



Safe work at the limit.

The SCORPION models 1033 and 741 to 635 are available with side support for the telescopic arm. This additional support provides for even greater safety when working at an extended reach and with extreme lever forces.

This also applies to asymmetrical pushing operations. When driving into bulk goods at an angle, the telescopic loading system can be subject to vast forces. The support relieves the central bolt to protect the machine and substantially increase the service life of the telescopic arm.



Side telescopic arm guide available for all SCORPION models

A firm eye on capacity utilisation.

The EN 15000-compliant load display is located on the A pillar for maximum visibility. Its clear icons always provide the operator with certainty about the load level the machine is currently operating in: Green indicates that everything is fine, green-amber that the stability limit has been reached and green-amber-red that there is a risk of tipping over.



Side telescopic arm guide integrated into the frame as standard with all telehandlers with load capacities above 4,500 kg



Load display based on clear traffic light icons: When the stability limit is exceeded, all of the LEDs light up, and an alarm tone sounds.

<p>Level 0 (latched)</p>	<p>The machine will not allow any loads above 100%. Once 100% has been reached, only load-reducing movements can be performed.</p>	<p>Level 1 (latched)</p>	<p>Level 2 (non-latching)</p>
	<p>The machine will allow loads above 100% in certain load conditions. Cannot be activated with lift angles above 50°.</p>	<p>Loads above 100% can be manually enabled for a limited time in exceptional situations. Level 2 is only available for 60 seconds at a time.</p>	

Saving you time. SMART LOADING.

Greater comfort.

SMART LOADING bundles a number of intelligent systems for machine optimisation in wheel loaders and telehandlers into a unique operator assistance package, providing maximum comfort and convenience for the operator for routine daily operations.

Precisely coordinated and individually adjustable functions optimise the entire loading cycle, boosting both the productivity and efficiency of your work processes. This means considerably less strain on the operator, machine and materials.

More assistance.

All SCORPION models are optionally available with automatic bucket return. This function is ideal for loading operations where the bucket is continually being returned to a position close to the ground. To reduce the workload involved, the operator can simply save the required dumping angle and call it up as needed by pushing a button on the joystick.

The SCORPION 960, 756 and 746 models feature an automatic shake function for the tilt cylinder as standard. This makes it considerably easier to empty sticky materials from the bucket and helps distribute free-flowing goods evenly.



Greater precision.

The SCORPION 960, 756 and 746 models can optionally be equipped with precision control for the working hydraulics. This ensures that you can stack goods accurately even at great heights and gives you fine control when working with hazardous goods or heavy loads. Simply operate a toggle switch to automatically reduce the speed of the working hydraulics by half.



Automatic bucket return for faster work close to the ground

Greater efficiency.

The DYNAMIC POWER assistance system in the SCORPION 960-746 automatically increases or decreases the diesel engine speed in line with the joystick angle. This makes loading cycles even faster and easier. A lower speed enhances operating safety and reliability, reduces operator strain and allows operators to work longer without getting fatigued.

Greater stability.

Oscillation damping of the telescopic arm prevents the machine from bouncing while it is on the move. This function can be activated via a toggle switch at any ground speed. In automatic mode, it is automatically switched off at speeds below 7 km/h for precise work even with heavy loads.



Whatever the requirement may be – heavy lifting or fast loading – the SCORPION has powerful working hydraulics with joystick operation (including electrohydraulic pilot control in VARIPOWER models) for maximum power and performance.

Proportional valves, which are load-independent in the VARIPOWER variant, provide precise control of all hydraulic functions in the loader unit.

Working hydraulics – VARIPOWER models.

SCORPION		960	756	746	741	736	635	1033	732
Pump design		Load sensing							
Valves		Load sensing (flow distribution independent of load pressure)							
Max. pump capacity	l/min	200	200	200	160	160	160	160	160
Max. operating pressure	bar	270	270	240	270	270	240	270	240

Strong up front.

For implements with a double-acting control circuit such as sweepers or grab buckets, the SCORPION has additional hydraulic control circuits with a capacity of up to 200 l/min. Two double-acting hydraulic connections can be safely attached directly to the implement carrier if required. A leakage oil line and pressure-free return are available as optional equipment.

- Convenient, independent activation via the joystick
- Infinitely variable flow rate adjustment
- Activation of continuous operation via a toggle switch

Versatile at the rear.

The SCORPION VARIPOWER comes with a choice of four different rear hydraulics options:

- Single-acting connection for tipper operation
- Single-acting connection and pick-up hitch
- Single-acting and double-acting connection
- Single-acting and double-acting connection plus pick-up hitch



Change implements easily and quickly.

For fast and easy implement changes with no unnecessary oil losses, the couplers must be pressure-free. Simply switch the connections of the third control circuit to zero pressure at the push of a button while the engine is running, either via a toggle switch in the cab or a push button on the telescopic arm.

Safe stacking of hazardous goods.

For high overhead loading operations, or for added safety in situations where the tilt cylinder must not be activated in any circumstances, you can simply activate the tilt cylinder lock from inside the cab. The implement carrier then remains in a horizontal position.

Well-protected hydraulic connections on the implement carrier



1 Front control circuit
2 Pressure relief



A great place to be. The workstation.



Comfort and visibility.

The spacious operator cab provides an optimal environment for working comfortably, safely and at top productivity, day in, day out. The cab design boasts a unique 360° all-round view. Inside, the functional design is focused on everything essential to ensure that operators are not distracted from the instruments in the control unit. You additionally have a wide choice of optional comfort extras for your SCORPION VARIPOWER model.

Plenty of comfort and greater productivity for every driver.

Plenty of space.

The cab design concept developed for the current SCORPION model range includes impressive features, from the access via individually adjustable steps to the comfortable interior with perfectly coordinated ergonomics.

- Spacious cab with plenty of room
- Tailored to operator requirements
- Maximum comfort in any operations



Perfect visibility.

The main objective in designing the cab was to give the operator a full 360° view, together with maximum comfort and plenty of storage space. Accordingly, the structural frame elements are kept as small as possible, and the telescopic arm is fitted to the chassis at the lowest possible point.

This structural design plus the large, low-cut windscreen give operators unobstructed all-round visibility. Implements are always in clear view, and operators are able to see what is happening behind the machine.



1 SCORPION 960-746
2 SCORPION 1033-635



Fresh air.

The split-level door in the SCORPION can be folded back and secured in the preferred position in a single move. It can also be closed without the operator needing to get in or out of the cab. The hinged rear window can also be fixed in an open position. Both of these features provide a much-welcome breath of fresh air, especially on hot days.

The upper section of the access door can be opened and locked in position. This provides a further substantial increase in visibility, particularly in difficult driving conditions. The lock can be quickly released, both from the outside and from the driver's seat.



Easy access to the driver's seat, individually adjustable work position



Perfect visibility of the implement, regardless of its position

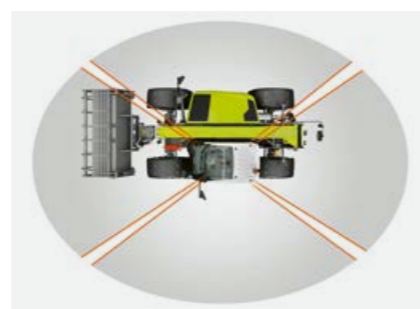

Full 360° visibility thanks to large windows



Unobstructed view to the rear thanks to the low-mounted telescopic arm – for safer work

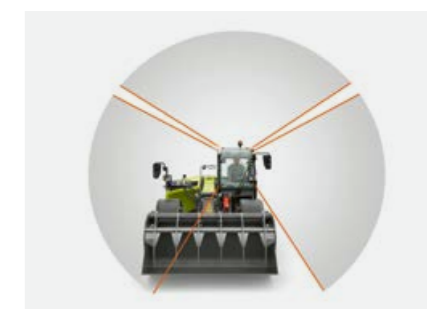

Unobstructed view of attached implements and the immediate work environment



Intuitive operation.

A robust control lever that allows proportional control of the basic functions. A clearly organised terminal that provides information on all important machine data at a glance. That's all you need to make your work with the SCORPION productive. The machine is intuitive to operate. Even inexperienced drivers quickly become familiar with this telehandler, regardless of whether they are working with the large or the small series.

Ergonomic joystick.

With the ergonomically designed joystick, you'll always control your machine securely, whatever the job at hand. Joystick operation makes it intuitive and easy to control the machine. Electronic pilot control makes for highly sensitive proportional control of all functions, ensuring that any loading and material handling jobs can be performed with great precision.

All controls are within easy reach of the operator's right hand. They are logically arranged by application and quickly activated. A colour-coded grouping of controls ensures even greater comfort and safety.

Informative terminal.

The 3.5" colour screen of the instrument cluster display serves as a central source of information for operating your machine. It is positioned within easy view of the operator and clearly readable in all lighting conditions.

Survey all the main parameters at a glance and see the current operating status of the machine and its components. The easily understandable sub-menus are intuitive to use. For the VARIPOWER models, a 7" colour display is optionally available.





Three-way adjustment for the steering column (height, angle and tilt)

In addition to the rear-view mirrors, interior rear-view mirrors and rear mirrors for the trailer coupling and hitch hook are available as optional equipment.



Seating comfort.

The SCORPION seat boasts air suspension or low-frequency suspension with seat heating, back extension and a wide range of individual adjustment options for maximum comfort. Alternatively, you can have a seat with mechanical suspension fitted in your SCORPION.

Seeing clearly.

To ensure that your all-round view is not obscured by ice, rain or dust, all models can be fitted with windscreen heaters for the rear window and right-hand side window, and with windscreen washers for the windscreen and roof window. For the SCORPION 960-746, a windscreen washer is also available for the right-hand side window.



Breathe freely.

The high-performance air-conditioning system of the SCORPION provides not only for comfortable conditions inside the cab even in very hot weather, but also for excellent protection against dust and aerosols. Temperature, fan speed and air distribution can all be set to individual preferences.



Well chilled and safely stored in the cooling compartment of the SCORPION 960-746



The roof window is fitted with a roll-up sun screen as standard



The all-seeing driver.

SCORPION machines can be fitted with high-resolution cameras upon request. These transmit sharply defined images of the work environment to the in-cab colour display even in twilight. The ultra-robust camera housing easily withstands high-pressure cleaning. An integrated heater prevents the lens from misting up or freezing over.

- Better visibility to the sides when driving with the lift mast raised
- More safety for people in the operating range
- Maximum control when reversing

The images from the front and rear cameras are transmitted to the monitor in the cab

Anti-theft protection.

Coded keys with integrated transponders protect the machine against theft. The SCORPION additionally gives you the option of CESAR security registration (availability subject to country).

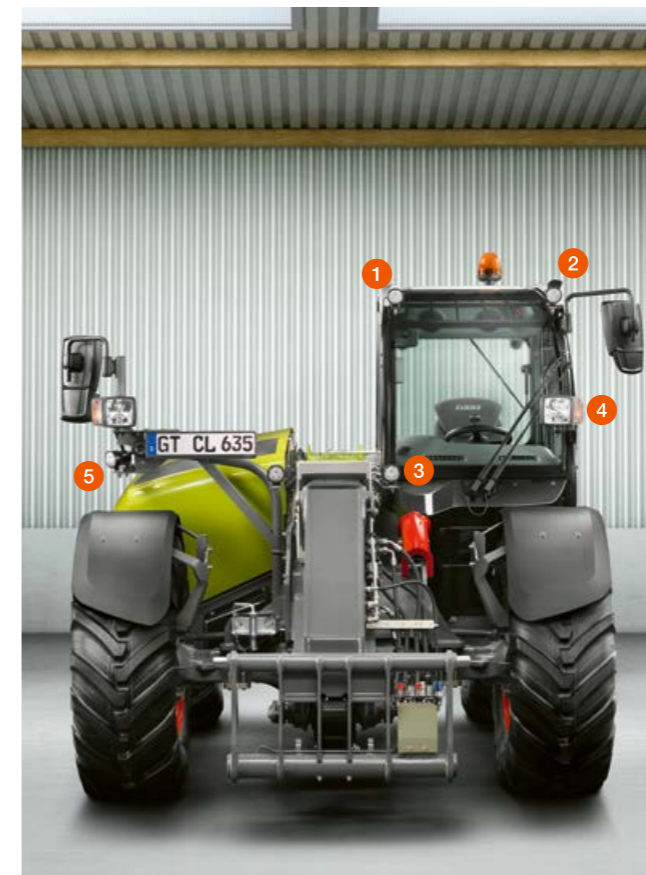

Light in every corner.

Pivoting LED work lights provide generous 360° lighting of the work environment for night work or when operating indoors in dark conditions. The long-life lights combine outstanding luminous intensity with low power consumption. The uniform light distribution and attractive near-daylight colours help to prevent fatigue.



Halogen lights on the rear mirror bracket for illuminating the rear of the machine

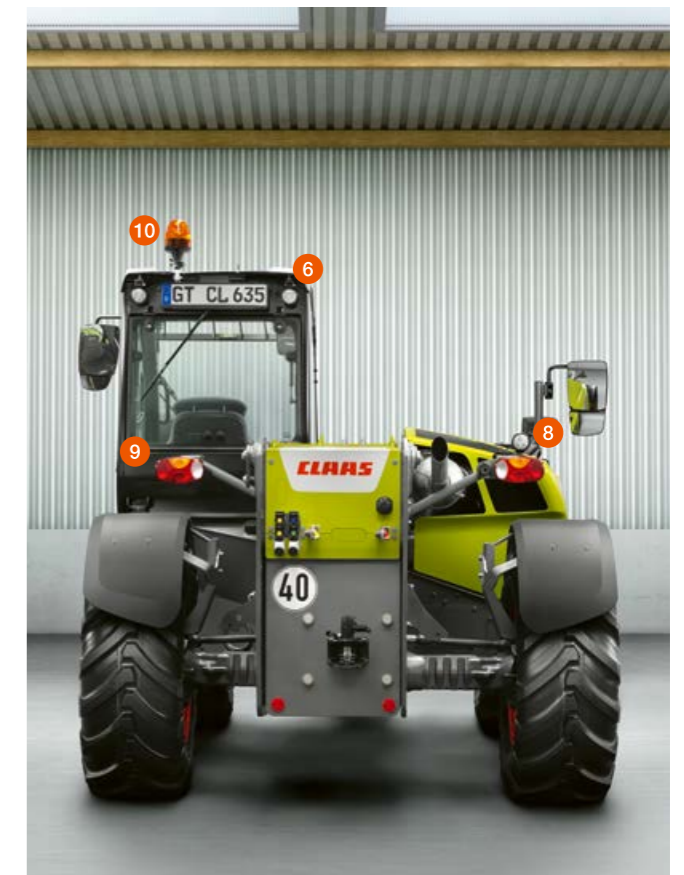

Choice of LED or halogen lights for comprehensive 360° illumination around the machine.

- 1 One halogen or two LED lights at the front of the cab roof
- 2 One LED side light at the left of the cab roof
- 3 Two halogen or LED work lights on the telescopic arm
- 4 Front road transport light and indicator
- 5 Three LED lights on the mirror bracket
- 6 One halogen or two LED lights at the rear of the cab roof
- 7 One halogen or LED light on the rear mirror
- 8 One halogen or LED work light on the rear right tail light
- 9 Reversing light and indicator
- 10 Rotating beacon



A well thought-out workspace.

The economical TREND models deliver high performance at a low cost. They are ideal for on-farm use as well as in your animal housing and barns.

These specialists for loading work can be operated just as easily and intuitively as the VARIPOWER models. They also have the same engine power and offer the same lifting heights and forces. However, since they are generally not used for prolonged pushing, pulling or transport work, their equipment is somewhat more economical.

- Spacious cab with plenty of room and unique 360° all-round visibility
- Clear and logical layout of instruments in the control unit
- Perfectly coordinated ergonomics both inside the cab and for cab access
- Plenty of storage space and compartments
- Range of seat variants available for different needs and preferences
- PROFI CAM camera system for a clear view even in poor visibility conditions



Easily readable display.

The 3.5" b/w matrix display makes for easy reading in any lighting conditions. All information is displayed clearly. The most important machine parameters are available at a glance:

- Direction and speed of travel
- Operating hours
- Status of various machine components



Ergonomic control lever.

The robustly designed control lever sits well in the hand and allows you to control the basic machine functions proportionally:

- Raise and lower the telescopic arm
- Control the dumping angle of the implement carrier
- Retract and extend the telescopic arm
- Change the direction of travel and put the ground drive into neutral
- Operate the auxiliary control circuit



Easily adjustable steering modes.

In the SCORPION TREND models, the steering mode is selected via a control lever positioned within easy reach of the operator, allowing operators to switch steering modes quickly and easily. The axles are synchronised with the assistance of LEDs.



Unobstructed access saves time.

The quicker it is to reach maintenance points, the more you can save on maintenance time and costs. In the SCORPION, all essential points are safely and easily reached from the ground, in a standing position and with no need to get dirty.

Many of the maintenance openings are located in the engine tray. All inspection points and fluid levels are within easy view, and the clearly laid out components in the engine compartment under the one-piece bonnet are readily accessible.

The engine air filter is in a clearly visible location on the right side of the machine. A warning icon is shown in the display if the filter becomes too severely soiled.



Good access to the fresh air filter for the cab



Central lubrication reduces costs.

Regular lubrication reduces wear. The automatic central lubrication system ensures that all maintenance intervals are scrupulously observed. Each lubrication point is continuously lubricated with an accurately dispensed quantity of grease while the machine is in operation. The transparent grease tank is located on the left side of the machine.

All SCORPION models¹ are available with preparation for a central lubrication system. All lines required for installing such a system later are then already routed through the machine.

A thorough approach makes for a longer service life.

With the optional central grease anchor blocks, three such blocks are provided at the rear right, at the front on the axle and in an easily accessible location on the gooseneck to deliver lubrication to the entire machine. As a result, even components in poorly accessible locations can be lubricated thoroughly, quickly and easily. With this option, the grease anchor blocks are mounted at the outside for easier access to all lubrication points and lines.

¹ Not available for the SCORPION 1033

Protection for electronics.

In all SCORPION models, the fuses are placed in a compartment in the cab, protected against dust and water. The cover panel can be removed without using tools, providing easy access to all fuses.

The battery and battery disconnecter are easily accessible, securely protected in a robust housing. The automatic battery disconnecter automatically disconnects the battery from the vehicle's electrical system after 120 seconds. This provides protection against battery discharge and safeguards the vehicle's electrical system against damage from voltage fluctuations.

At the rear, the SCORPION has a 7-pin socket for trailer operation. A 4-pin socket is provided at the front, on the mast, for operating sweepers and other attached implements.



Sockets for a flexible power supply to a wide range of attached and trailed implements



The engine air filter is very readily accessible, with no tools required for maintenance

Whatever it takes – CLAAS Service & Parts.



Greater reliability for your machine.

Increase your operational reliability, minimise the repair and breakdown risk. MAXI CARE offers you predictable costs. Create your own individual service package to meet your particular requirements.

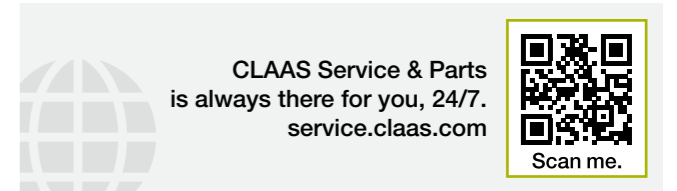

Specially matched to your machine.

Precision-manufactured parts, high-quality consumables and useful accessories. Choose our comprehensive product range to be certain to receive precisely the right solution and ensure that your machine is 100% reliable.



For your business: CLAAS FARM PARTS.

CLAAS FARM PARTS offers one of the most comprehensive ranges of multi-brand parts and accessories for all agricultural applications on your farm.



Global supply.

The CLAAS Parts Logistics Center in Hamm, Germany, stocks almost 200,000 different parts and has a warehouse area of over 183,000 m². This central spare parts warehouse delivers all ORIGINAL parts quickly and reliably all over the world. This means that your local CLAAS partner can supply the right solution for your harvest or your business within a very short time.



Your local CLAAS distributor.

Wherever you are, you can count on us to always provide you with the service and the contact persons you need. Your CLAAS partners are on hand in your local area, ready to support you and your machine around the clock. With know-how, experience, commitment and the best technical equipment. Whatever it takes.

SCORPION 960

Load capacity chart with load centre
(LC) 600 mm

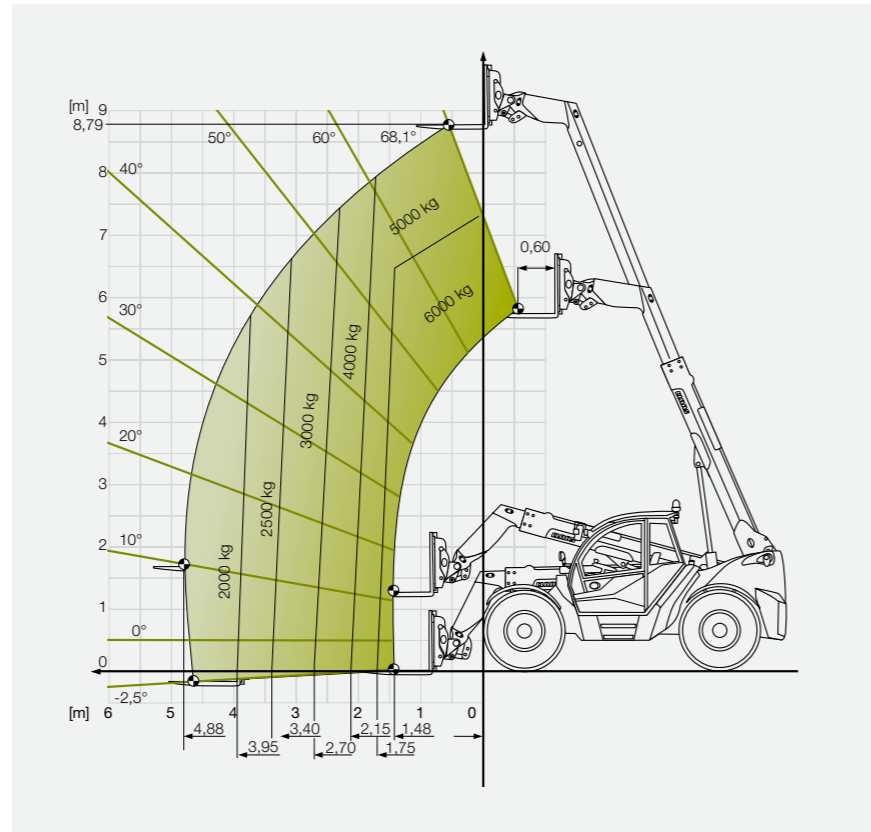

SCORPION 746

Load capacity chart with load centre
(LC) 500 mm

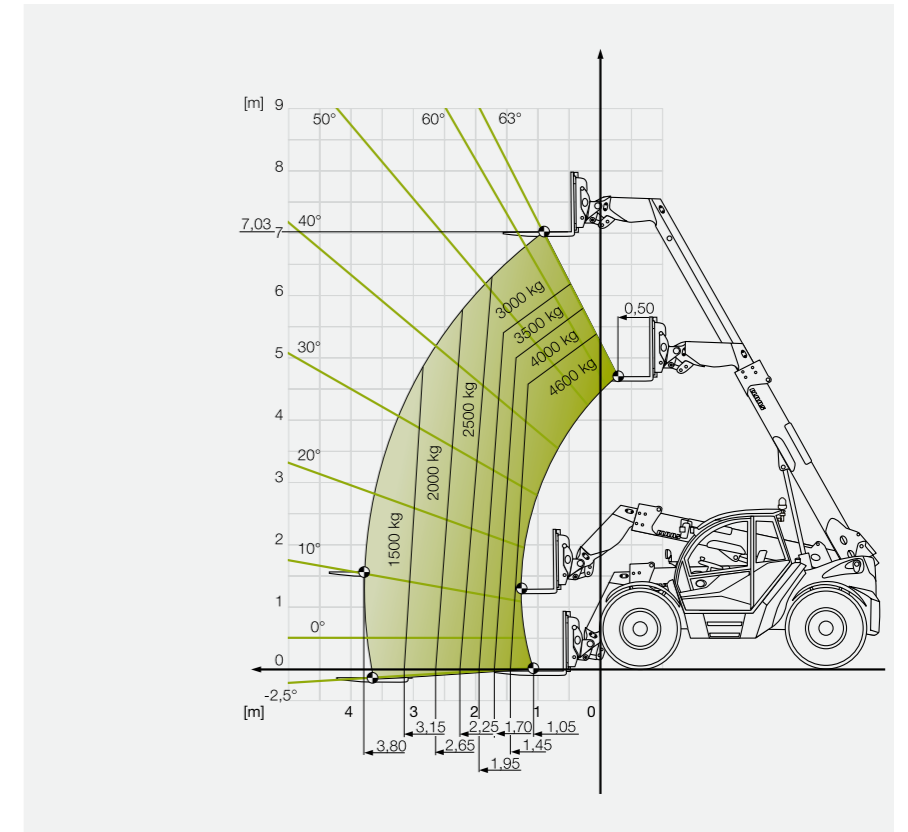

SCORPION 756

Load capacity chart with load centre
(LC) 600 mm

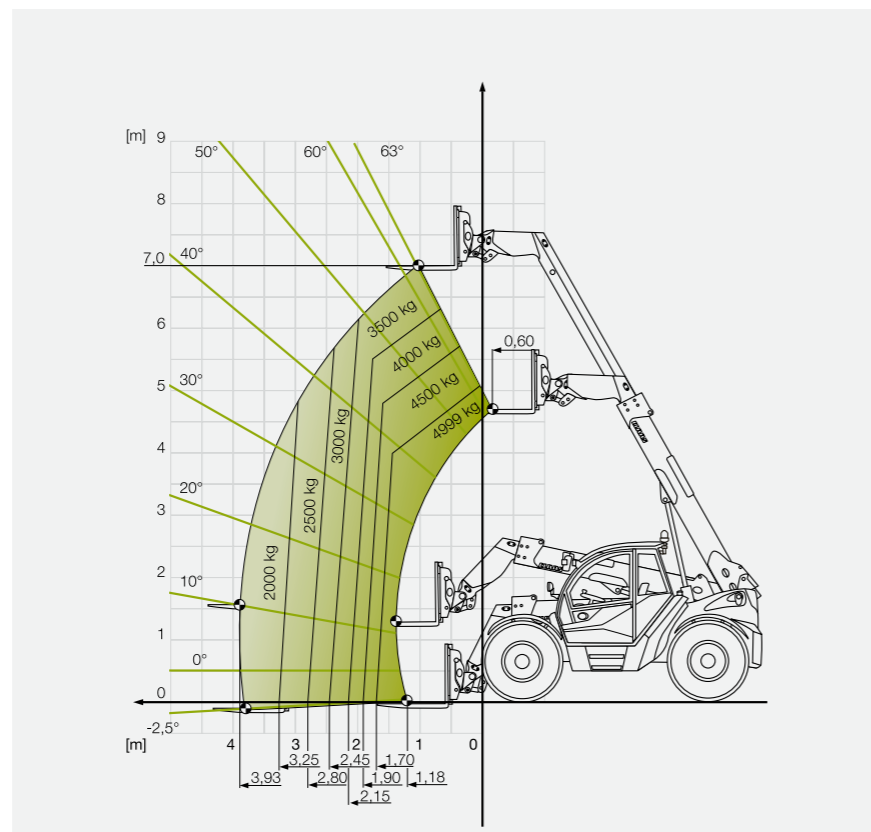

SCORPION 741

Load capacity chart with load centre
(LC) 500 mm

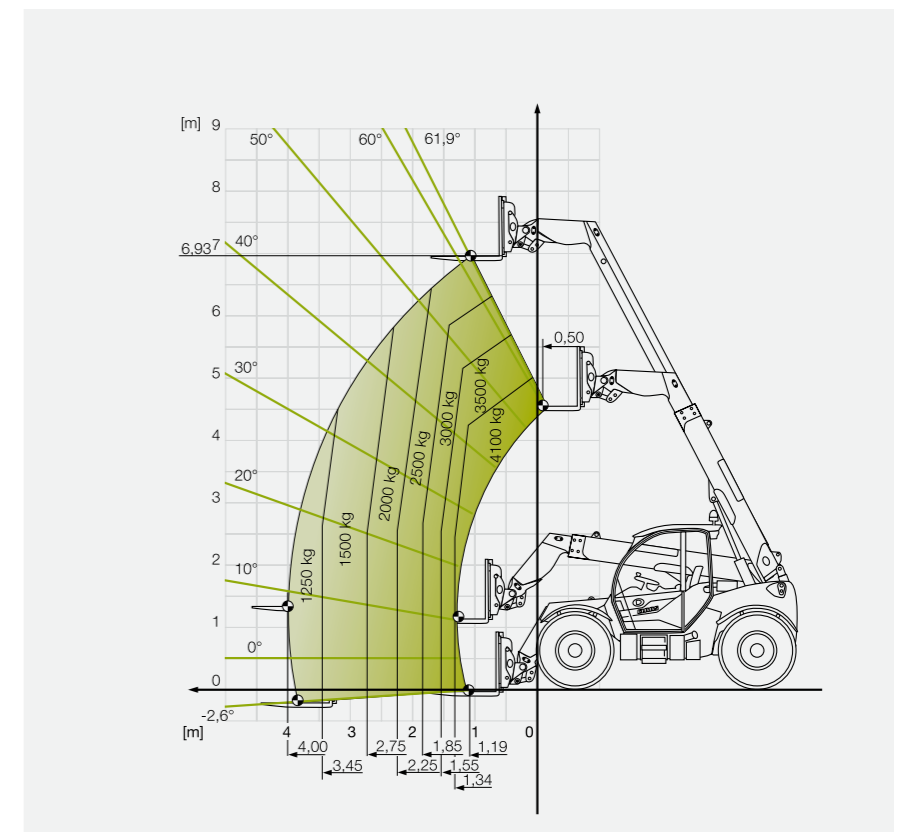

SCORPION 736

Load capacity chart with load centre
(LC) 500 mm

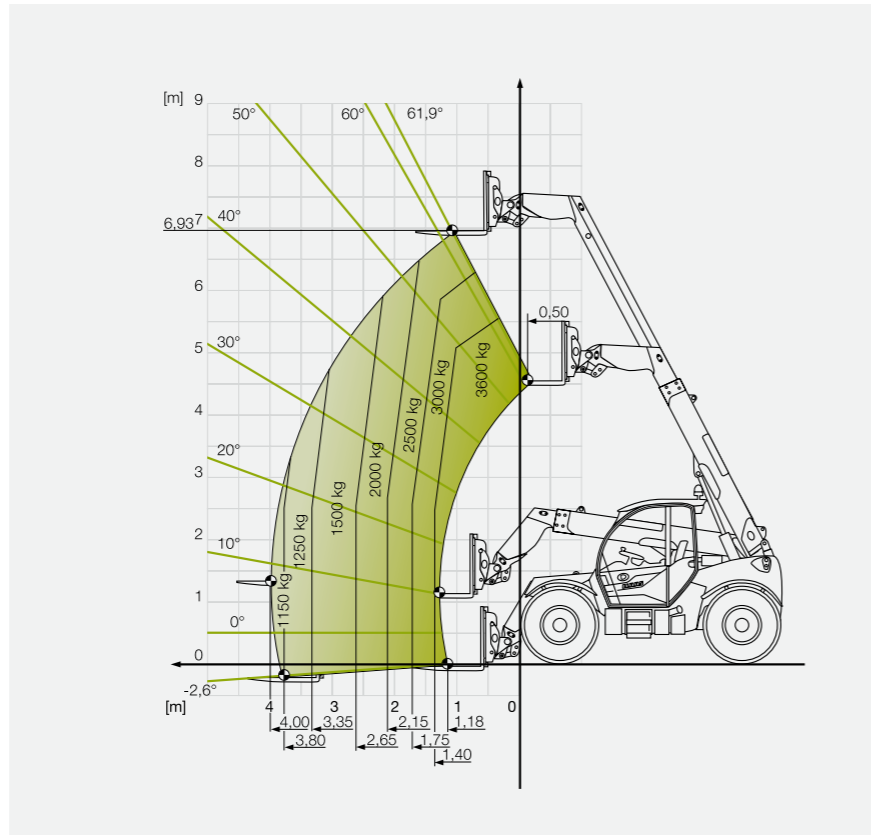

SCORPION 1033

Load capacity chart with load centre
(LC) 500 mm

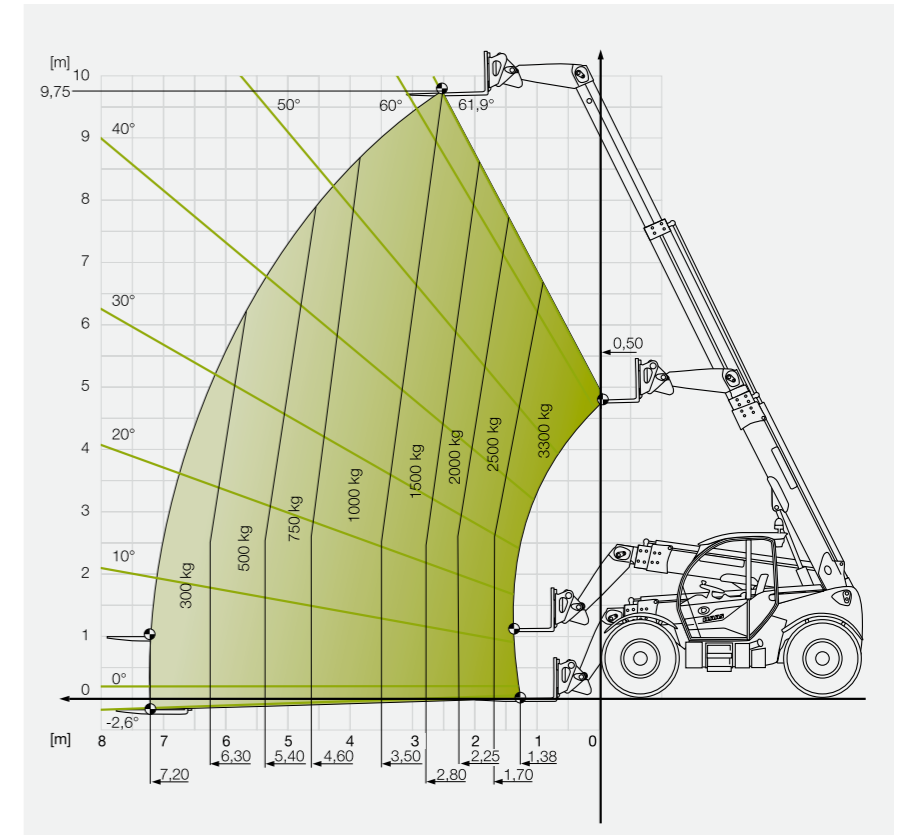

SCORPION 635

Load capacity chart with load centre
(LC) 500 mm

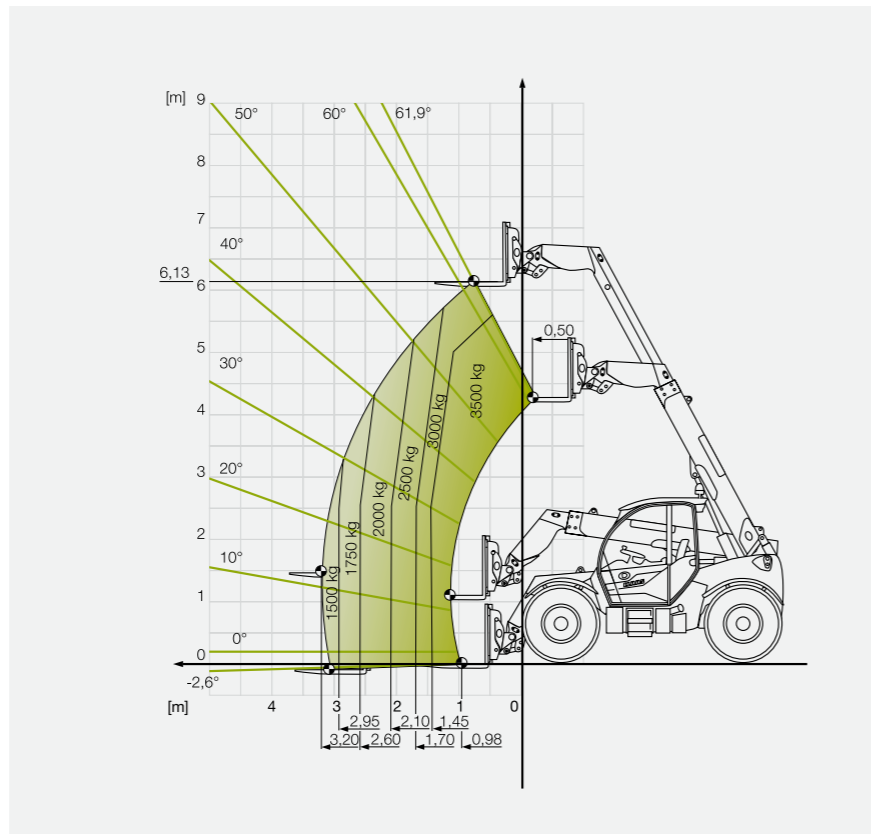

SCORPION 732

Load capacity chart with load centre
(LC) 500 mm

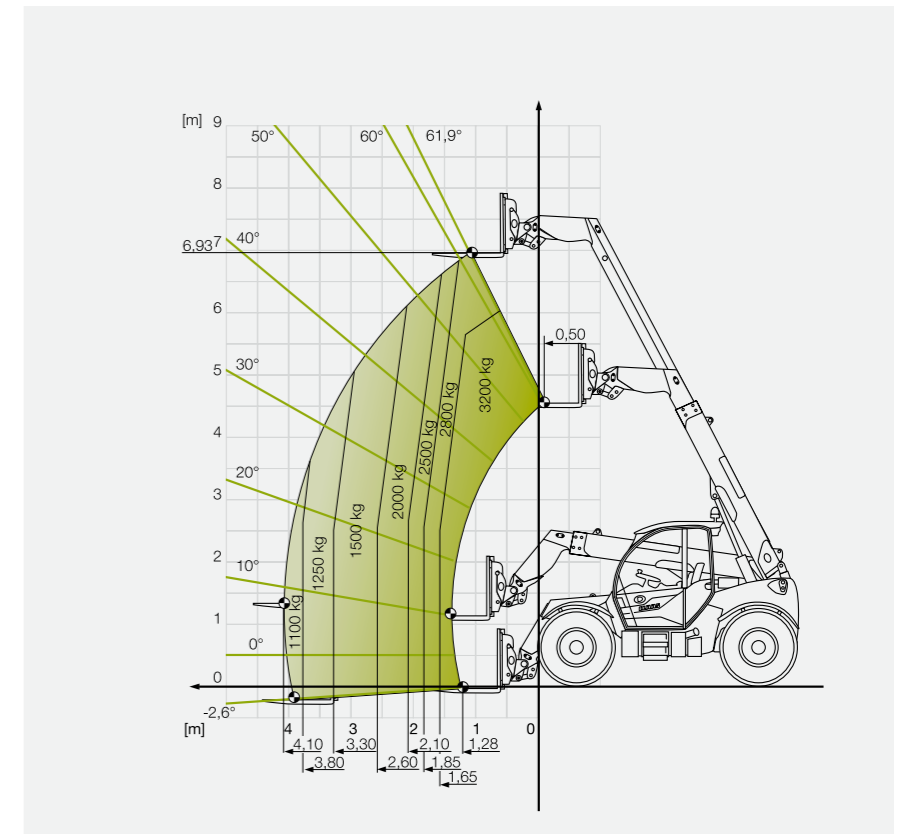

Delivering impressive benefits.



Drive train.

- High-torque Deutz engines delivering up to 115 kW/156 hp
- Efficient hydrostatic ground drives for maximum power and great accuracy
- Infinitely variable driving up to 40 km/h
- Improved SMART ROADING for minimum-noise operation and reduced fuel consumption from only 1,900 rpm
- Hand throttle with creep-speed facility
- Intelligent parking brake for maximum comfort and convenience
- Manual crab steering as fourth steering mode

Loader unit.

- Lift capacities from 3.2 to 6.0 t
- Lift heights from 6.13 to 9.75 m
- Powerful working hydraulics with up to 200 l/min
- Oscillation damping with automatic function
- External pressure relief for the third control circuit

Operator assistance systems.

- SMART LOADING with automatic bucket return, shake function for the tilt cylinder
- DYNAMIC POWER and fine-tuned control of the working hydraulics for optimal precision

Cab.

- Cab concept for outstanding ergonomics and safety with maximum all-round visibility
- 3.5" or 7" colour display
- Steering column with three-way adjustment
- PROFI CAM camera system for a clear view even in poor visibility conditions

SCORPION			960	756	746	741	736	635	1033	732
Dimensions										
A	Length including implement carrier	mm	5760	5030	5002	4752	4752	4452	4950	4752
B	Overall width (without mirror)	mm	2521 ¹	2521 ¹	2514 ¹	2380 ¹	2380 ¹	2380 ¹	2380 ¹	2380 ¹
C	Cab width (exterior)	mm	969	969	969	941	941	941	941	941
D	Track width	mm	1950-2040 ²	1950-2040 ²	1950-2040 ²	1920	1920	1920	1920	1920
E	Overall height (without warning beacon)	mm	2622	2590	2590	2465	2465	2465	2465	2465
F	Wheelbase, middle	mm	3150	2950	2950	2850	2850	2750	2850	2750
G	Ground clearance	mm	438	410	410	405	405	405	405	405
H	Turning radius over wheels ³	mm	4090	3902	3833	3906	3906	3812	3906	3812
I	Distance front-wheel centre line to front of implement carrier	mm	1108	1177	1177	1272	1272	1073	1471	1372
J	Rear overhang (without trailer hitch)	mm	1217	1019	977	784	784	784	784	784
K	Height to telescopic arm articulation point in frame	mm	1848	1693	1693	1530	1530	1530	1530	1530
L	Rear approach angle	°	29	32	32	46	46	46	46	46
M	Pallet fork tilt-in angle, bottom	°	20	20	20	13	13	13	12	13
N	Pallet fork tipping angle, top	°	64.0	66.4	66.4	44.0	44.0	44.0	20.0	44.0
	Total implement carrier rotation angle	°	152	152	152	150	150	150	126	150

¹ 460/70 R 24

² May also be dependent on tyres

³ Theoretical value, turning radius varies according to tyres

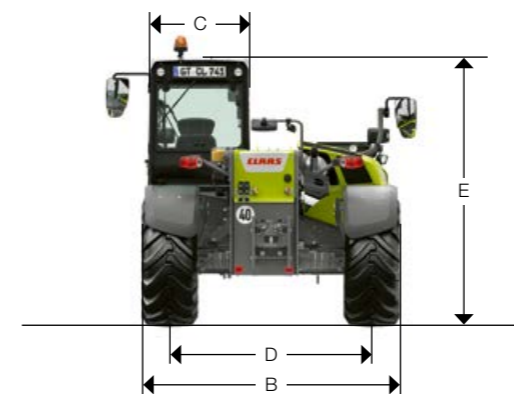
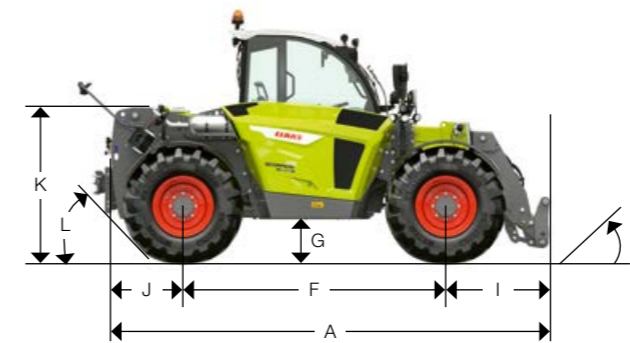

SCORPION		960	756	746	741	736	635	1033	732
Loader unit									
Lift capacity	kg	6000	5600	4600	4100	3600	3500	3300	3200
Lift height	mm	8780	7030	7030	6930	6930	6130	9750	6930
Engine									
Manufacturer		Deutz	Deutz	Deutz	Deutz	Deutz	Deutz	Deutz	Deutz
Model		TCD 4.1 L4	TCD 4.1 L4	TCD 3.6 L4	TCD 3.6 L4	TCD 3.6 L4	TCD 3.6 L4	TCD 3.6 L4	TCD 3.6 L4
Layout / number of cylinders		R 4	R 4	R 4	R 4	R 4	R 4	R 4	R 4
Displacement	cm ³	4038	4038	3621	3621	3621	3621	3621	3621
Output at 2300 rpm (ECE R 120) ¹	kW/hp	115 / 156	115 / 156	100 / 136	100 / 136	100 / 136	100 / 136	100 / 136	100 / 136
Max. torque at 1600 rpm	Nm	609	609	500	500	500	500	500	500
Exhaust gas aftertreatment Stage V		SCR / DOC-DPF							
Exhaust gas aftertreatment Stage IIIA (Tier 3)		without SCR / DOC-DPF							

VP working hydraulics

LS pump, load-sensing (LS) valves	l/bar	max. 200/270 ²	max. 200/270 ²	max. 200/240 ²	160/270 ³	160/270 ³	160/240 ³	160/270 ³	160/240 ³
Spool valve		4x (standard), 5x (option)			4x (standard), 5x (option)				
Pressure release, third control circuit		o	o	o	o	o	o	o	o

VP ground drive

Hydrostatic		VARIPOWER PLUS	VARIPOWER PLUS	VARIPOWER	VARIPOWER 2				
Driving ranges ⁴	km/h	0-15/0-30/ 0-40 ⁵	0-15/0-30/ 0-40 ⁵	0-15/0-30/ 0-40 ⁵	0-15/0-30/ 0-40 ⁵	0-15/0-30/ 0-40 ⁵	0-15/0-30/ 0-40 ⁵	0-15/0-30/ 0-40 ⁵	0-15/0-30/ 0-40 ⁵
Max. top speed ⁶	km/h	30/40 ¹	30/40 ¹	30/40 ¹	30/40 ¹	30/40 ¹	30/40 ¹	30/40 ¹	30/40 ¹

TREND hydraulics

Gear pump and throttle valves	l/bar	–	–	–	106/270	106/270	106/240	106/270	106/240
Ground drive	Type/Vmax	–	–	–	Hydrostat/30				

Tank capacity overview

Fuel tank	l	190	190	190	150	150	150	150	150
Urea tank	l	20	20	10	10	10	10	10	10
Hydraulic oil tank	l	260	230	230	140	140	140	140	140

Axles

Front axle									
Front differential lock		100% locking differential			45% self-locking differential				
Steering lock	°	40	40	40	35	35	35	35	35
Hydraulic levelling +/-	°	8	–	–	–	–	–	8	–
Rear axle									
Angle of oscillation	°	10			11				
Steering lock	°	40	40	40	35	35	35	35	35

Service brake

Type		Foot-operated hydraulic power brake (closed-circuit, wet)			Foot-operated hydraulic power brake (closed-circuit, wet)				
Location		Front and rear axle			Front axle				

Parking brake

Type		Electrohydraulic disc brake			Electrohydraulic disc brake				
Location		Spring-type actuator in the front axle			Spring-type actuator in the front axle				

Weights

Kerb weight	kg	11700	10600	8995	7640	7420	7510	8230	7585
Maximum permissible gross weight	kg	13000	13000	12000	8600	8600	8600	8600	8600

SCORPION		960	756	746	741	736	635	1033	732
SMART LOADING / electronics expertise									
Automatic bucket return		o	o	o	o	o	o	o	o
DYNAMIC POWER		o	o	o	–	–	–	–	–
Precision control of working hydraulics		o	o	o	–	–	–	–	–
TELEMATICS		o	o	o	o	o	o	o	o
Tilt cylinder shake function		●	●	●	–	–	–	–	–

SCORPION		960	756	746	741	736	635	1033	732
Tyre sizes									
Vehicle width⁷									
405/70-20 Mitas MPT 01, agricultural tyres	m	–	–	–	2.38	2.38	2.38	2.38	2.38
400/70-24 Mitas MPT 04, agricultural tyres	m	–	–	–	2.38	2.38	2.38	2.38	2.38
405/70-24 Mitas MPT 01, agricultural tyres	m	–	–	–	2.38	2.38	2.38	2.38	2.38
405/70-24 Mitas MPT 04, agricultural tyres	m	–	–	–	2.33	2.33	2.33	2.33	2.33
405/70 R 24 Dunlop SP SPT9, multi-purpose tyres	m	–	–	–	2.38	2.38	2.38	2.38	2.38
440/80 R 24 Michelin Power CL, agricultural tyres	m	2.50	2.50	2.50	–	–	–	–	–
460/70 R 24 Firestone Duraforce Utility, industrial tyres	m	–	–	2.50	2.39	2.39	2.39	2.39	2.39
460/70 R 24 Michelin XMCL, agricultural tyres	m	–	2.51	2.51	2.39	2.39	2.39	2.39	2.39
460/70 R 24 Alliance A580, agricultural tyres	m	–	2.50	2.50	2.39	2.39	2.39	2.39	2.39
460/70 R 24 Michelin Bibload, multi-purpose tyres	m	–	2.51	2.51	2.39	2.39	2.39	2.39	2.39
500/70 R 24 Alliance Multiuse, multi-purpose tyres	m	2.52	2.52	2.52	–	–	–	–	–
500/70 R 24 Alliance A580, agricultural tyres	m	2.52	2.52	2.52	2.44	2.44	–	–	–
500/70 R 24 Nokian TRI2, multi-purpose tyres	m	2.51	2.51	2.51	–	–	–	–	–
500/70 R 24 Michelin XMCL, agricultural tyres	m	2.52	2.52	2.52	2.44	2.44	–	–	–
500/70 R 24 Michelin Bibload, multi-purpose tyres	m	2.52	2.52	2.52	–	–	–	–	–
500/70 R 24 Firestone Duraforce Utility, industrial tyres	m	–	–	2.52	2.43	2.43	–	–	–
480/80 R 26 Michelin XMCL, agricultural tyres	m	2.51	–	–	–	–	–	–	–
480/80 R 26 Michelin Bibload, multi-purpose tyres	m	2.52	–	–	–	–	–	–	–
600/55-26.5 Alliance I-3 16PR, agricultural tyres	m	2.54	2.54	2.54	–	–	–	–	–

¹ Compliant with ISO 14396

² From only 2200 rpm

³ From only 1900 rpm

⁴ With a maximum top speed of 30 km/h in combination with the VARIPOWER PLUS / VARIPOWER ground drive, the tortoise speed range is 0–22 km/h.

⁵ All VARIPOWER models are also available as 30 km/h variants.

⁶ All models are also available as 20 km/h variants irrespective of the transmission type

⁷ About tyres

CLAAS continually develops its products to meet customers' practical needs. This means that all products are subject to change without notice. All descriptions and specifications in this brochure should be considered approximate and may include optional equipment that is not part of the standard specifications. This brochure is designed for worldwide use. Please refer to your nearest CLAAS distributor and their price list for local specification details. Some protective panels may have been removed for photographic purposes in order to illustrate functions. To avoid any risk or danger, never remove these protective panels yourself. In this respect, please refer to the relevant instructions in the operator's manual. All technical specifications relating to engines are based on the European emissions regulation standards: Stage. Any reference to the Tier standards in this document is intended solely for information purposes and ease of understanding. It does not imply approval for regions in which emissions are regulated by Tier.



CLAAS UK
Saxham
Bury St. Edmunds
Suffolk
IP28 6QZ
Tel 01284 763100
claas.co.uk
info-uk@claas.com

365FarmNet enables you to manage your entire agricultural business by means of a single, non-proprietary software solution. Interfaces to intelligent applications created by partners in the agricultural sector offer expert support for your business 365 days a year.
CLAAS is a 365FarmNet partner.

www.365farmnet.com



365FarmNet